



340i / 680i / 1220i DC Motor Controller Product Manual

This drive is an isolated single direction speed controller for shunt wound or permanent magnet motors. It utilises speed feedback from the armature voltage (Avf), or from a shaft mounted tachogenerator. It incorporates a fully controlled thyristor bridge with a current loop to protect the drive and motor. It can be used in speed or current control modes. The drive can motor forward and will regenerate for reverse rotation by an external force. Please obtain expert help if you are not qualified to install this equipment. Make safety a priority. **This component is hazardous.** (All specifications in this document are nominal).

POWER RATING

340i	0.55KW (0.5 HP) at 180 Volts DC, 3.4 Amps
680i	0.75KW (1.0 HP) at 180 Volts DC, 6.8 Amps
1220i	1.80KW (2.0 HP) at 180 Volts DC, 12.2 Amps

(The KW / HP ratings are typical motor ratings at or below the available terminal rating of Watts= AV x IA)
Versions that work from 60V / 30V AC supply are also available.

340i / LV60, 680i / LV60, 1220i / LV60.

For motors rated up to 48V DC

MAXIMUM OUTPUT

Armature: 200 Volts DC. or 50V DC for LV60 models
Models 340i / 680i / 1220i --- 3.4/ 6.8/ 12.2 Amps.
Field: Volts DC=0.9 x AC supply volts. 1 Amp Max.
(0.45 x AC for field connected to F- and N). 1 Amp Max.

AC SUPPLY INPUT

110V AC or 240V AC +/-10%, 50-60 Hz.
30V AC or 60V AC +/-10%, 50-60Hz for LV60 models.

SPEED RANGE

Speed range 0-100%. (motor dependant)
Load Regulation typically 0.2% tach, 2% Arm Volts.

USER ADJUSTMENTS

Presets accessible under lift up cover.
Clockwise rotation for linear increase in parameter.

Relay driver threshold (Level)
Maximum Speed (Max spd)

Minimum Speed (Min spd)
Up Ramp (Ramp) ↑
Down Ramp (Ramp) ↓
Stability (Stab)
Maximum Current (I max)
IR compensation (IR comp)

+/- (0.5% to 105%). (+/-10.5V) Symmetrical about zero.
40V-200V span with Spd x 2 switch. (Avf/Tach fb volts)
LV60 models have an Avf range 10 - 50V.
0 to 30% of maximum speed. (With 10K external pot).
20 to 1 seconds up ramp rate. (For 0 to +10V)
20 to 1 seconds down ramp rate (For +10 to 0V)
Gain 1 to 10
0 to 100% current limit.
0 to 25%

EXTERNAL CONTROLS

Speed setpoint from external 10K Ohms pot.
External RUN contact for electronic STOP/START.
Built in functions are +/- channel with pushbutton control inputs, and relay driver with variable threshold. There is a pot kit available with graduated dial and knob.

CONTROL ACTION

Speed loop: Full P+I armature voltage or tach feedback.
Current loop: Full P+I isolated current feedback.

INSTALLATION

Use correctly rated cable minimum 600V AC,
1.5 times armature current.

FUSING REQUIREMENT

Semi-conductor fuse parts.
 20A fuse 6 X 32 CH00620A
 Fuseholder 6 X 32 CP102071
 DIN rail clip for fuseholder FE101969

Suitable for use on a circuit capable of delivering not more than 5000A RMS symmetrical amperes when protected by an Ar class fuse.

WARNING The drive can only be protected by fitting an external AC supply semi-conductor fuse with an I²t rating below 150 A²s.

CONTROL SIGNALS

Control signals are isolated from the supply, and the unit may be connected to other isolated instruments.

MECHANICAL

The unit is designed to clip onto a DIN rail. Avoid vibration and ambient temperatures outside -10 and +40C. Protect the unit from pollutants. Ensure there is an adequate supply of clean cool air to ventilate the unit and the enclosure it is mounted in. (Dissipation in Watts = 5 x Armature Amps).

MOTOR

Foot mounted motors must be level and secure. Protect motors from ingress of foreign matter during installation. Ensure accurate alignment of motor shaft with couplings. Do not hammer pulleys or couplings onto the motor shaft.

Before running motor, complete the following check list. (**Warning isolate the supply first**).

- 1) Correct insulation between all motor windings and earth. Disconnect all drive cables.
- 2) Check inside connection box for foreign objects, damaged terminals etc.
- 3) Check that brushes are in good condition, correctly seated and free to move in brush boxes. Check correct action of brush springs.
- 4) Motor vents must be freed of any obstruction or protective covers prior to running.

AC SUPPLY

To avoid damage, ensure the supply selection jumper on the drive matches the incoming supply. 110V or 240V AC.
 For models with LV60 suffix 30V AC or 60V AC.

PRESET POT settings

Set the I max (Max Current) preset to approximately match the motor armature rating. Fully clockwise is 100% drive rating. (340i 3.4A, 680i 6.8A, 1220i 12.2A). Fully anticlockwise is 0%. E. g. for a 340i unit a midway setting is 50% i.e. 1.7A. More accurate setting requires a suitable current meter in series with the armature. Set the Stab preset midway. (Clockwise rotation of the stab preset increases gain, excessive rotation may lead to instability).

Set all the other presets anticlockwise to start off with. (Note LV60 models avf range 10-50V)

The preferred strategy for initial commissioning is in armature voltage feedback mode described as follows. Set Avf/Tach switch ON (left) for armature voltage feedback (Avf) and Spd x 2 switch OFF (right) for 40V max feedback. For systems utilising tach feedback, remove the terminal 11 tach connection and temporarily make wire end safe until later.

POWER ON

Check that the Power lamp lights. Close the run contact. Increase the external speed pot slowly to maximum.

around 40V on the motor armature. (10V for LV60 models). Now set the correct 100% armature voltage and hence speed by using the Spd x 2 switch (ON (left) for speed X 2) and the Max spd preset (Clockwise to increase speed). Note, if you change the Spd x 2 switch position whilst running, the speed will undergo an immediate step change.

RAMP and MIN SPEED

The up / down ramps can now be set between 20 and 1 seconds, and the Min spd adjusted up to 30%. (Note, down ramp becomes up ramp for negative input).

IR COMP

Speed droop on heavy loads may occur when armature voltage feedback is used. This is compensated for by clockwise rotation of **IR comp**. Excessive rotation may lead to instability.

Note, **IR comp** is not used with tach feedback, leave preset anticlockwise.

TACH FEEDBACK

The tach feedback signal on terminal 11 must be negative with respect to terminal 10 **COMMON**.

Whilst still in AVF mode measure the tach volts on the wire intended for T11, when running at 100% speed. (**Warning**, possible high voltage). This is the tach full speed voltage. Make a note of it to assist in selecting the speed range. **Stop the motor and turn off the supply**. Set **Avf/Tach** switch OFF (right). Adjust the **Max spd** preset anti-clockwise. (With **Spd x 2** switch OFF (right) maximum speed range = 40 to 100V. With **Spd x 2** switch ON (left) the maximum speed range = 80 to 200V). Re-connect the tach wire to T11, re-start and adjust **Max spd** as required.

TERMINAL LISTING

- 1 +10V output. 10mA max. (Use a 10K Ohm pot for external speed reference).
 - 2 **MIN SPEED**. (Bottom end of external pot. 5K Ohms preset to common).
 - 3 **IP**. Speed input. 0 to +/-10V speed input from pot wiper. 47K internal pull down.
 - 4 **OP+/-**. +/-10.5V range. Input from T6. Invert with pushbutton input T8 open. Non-invert with pushbutton input T7. 10mA max.
 - 5 **COM**. Common. (0 Volts)
 - 6 **IP+/-**. Input to pushbutton controlled +/- signal channel. OP on T4. 50K Ohms impedance for invert mode, 10M input impedance in non-invert mode.
Note. This channel can invert input signals in the range +/-10.5V. It can also buffer (i.e. non-invert) signals in the range 0V to +10.5V. (**It cannot buffer negative signals**. If you try to buffer a negative signal the output will be positive).
Note. If using a high resistance external pot for positive signals e.g. greater than 20KOhms, then this channel can be used to buffer it using the non-invert mode.
 - 7 **PB+** Pushbutton input. 47K Ohm pull up to +12V. Connect to T5 **COM**. Latches T4 to buffer (**non-invert**) positive T6 signals when opened, provided T8 **PB-** is connected to T5 **COM**.
 - 8 **PB-** Pushbutton input. 47K Ohm pull up to +12V. Connect to T5 **COM**. Latches T4 to invert T6 when opened. T7 **PB+** may be open or connected to T5 **COM**.
 See truth table below for T7 and T8 operation. See terminal 6 **IP+/-** for notes.
- | PB+ Terminal 7 | PB- Terminal 8 | Input T6 to output T4 mode |
|-----------------------|-----------------------|--|
| Closed to Common | Open circuit | Invert (+/-10.5V range) |
| Closed to Common | Closed to Common | Remains in prevailing mode.
Powers up in invert mode. |
| Open circuit | Closed to Common | Non-invert (0 to +10.5V range) |
| Open circuit | Open circuit | Invert (+/-10.5V range) |
- a) Hence if **PB+ Terminal 7** remains open then a switch on **PB- Terminal 8** can be used to change modes.
 - b) If both **PB+ Terminal 7** and **PB- Terminal 8** remain open then the invert mode is established.
 - c) If both **PB+ Terminal 7** and **PB- Terminal 8** are connected to common then the desired mode can be established by momentarily opening **PB+ Terminal 7** for non-invert, or **PB- Terminal 8** for invert mode. The mode remains latched when the common connection is re-established.
 - 9 **RUN**. Internal 12K pull up to +12V. Open to stop, close to COMMON to run. **WARNING**. **RUN** is an electronic inhibit function. The field remains energised, and all power terminals 'live'. **RUN** must not be relied on to ensure the machine is stationary during hazardous operations. Remove the power source to the system.
 Opening T9 **RUN** will cause immediate drive inhibit and hence if the motor is rotating at the time it will coast to zero speed.
 - 10 **COM**. Common. (0 Volts)
 - 11 **TACH** input. The tach must be opposite polarity to speed input. 1.5 MOhms.

Will accept full scale feedback voltages between 40V-200V using Spd x 2 switch with **Max spd** preset.

12 **RLOP**. Relay driver. +10.5V active high. Flywheel diode to COM.

Note. The output is current limited. When in current limit, the output voltage achieved, depends on the resistance of the load multiplied by the available current limit at that voltage, according to the table below.

Output voltage	Typical current lim	Typical load resistance
10.5V	1mA	Greater than 10K Ohms
10.0V	10 mA	1000 Ohms
9.5V	15 mA	633 Ohms
9.0V	20 mA	450 Ohms
8.5V	25mA	340 Ohms
8.0V	30mA	267 Ohms

When driving relays, ensure the coil operating range is suitable. E. g. a 12V relay with a coil operating range of 80-110% will energise at voltages of 9.6V and above (80% of 12V).

Hence it must have coil resistance greater than 633 Ohms for the output to be capable of achieving the desired voltage. A suitable UL approved relay is Hongfa type HF41F/9... (In UK from Hawco).

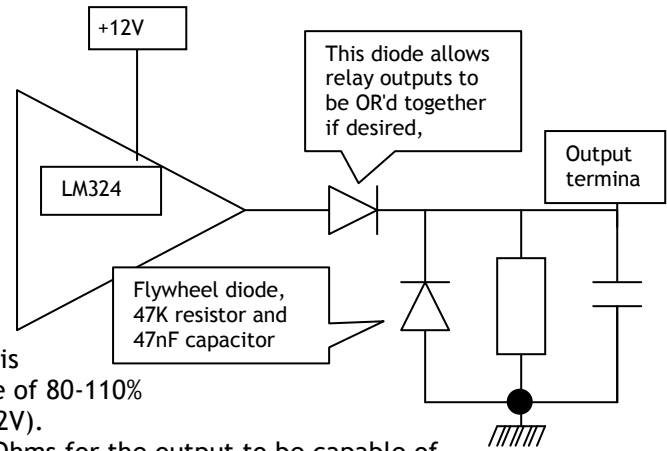

- 13 **RLIP**. Relay driver input. Accepts 0 to +/- 10.5V signal inputs. The threshold to activate the relay driver is symmetrical around zero, and set by the RELAY preset between +/- 0.05V and +/-10.5V. When the T13 input exceeds the positive or negative threshold, then the T12 RELAY DRIVER OUTPUT is turned ON. Typical uses include zero speed detector, zero current detector, stall detector etc.. The input will accept any output provided on other control terminals. 50K Ohm pull down to common.

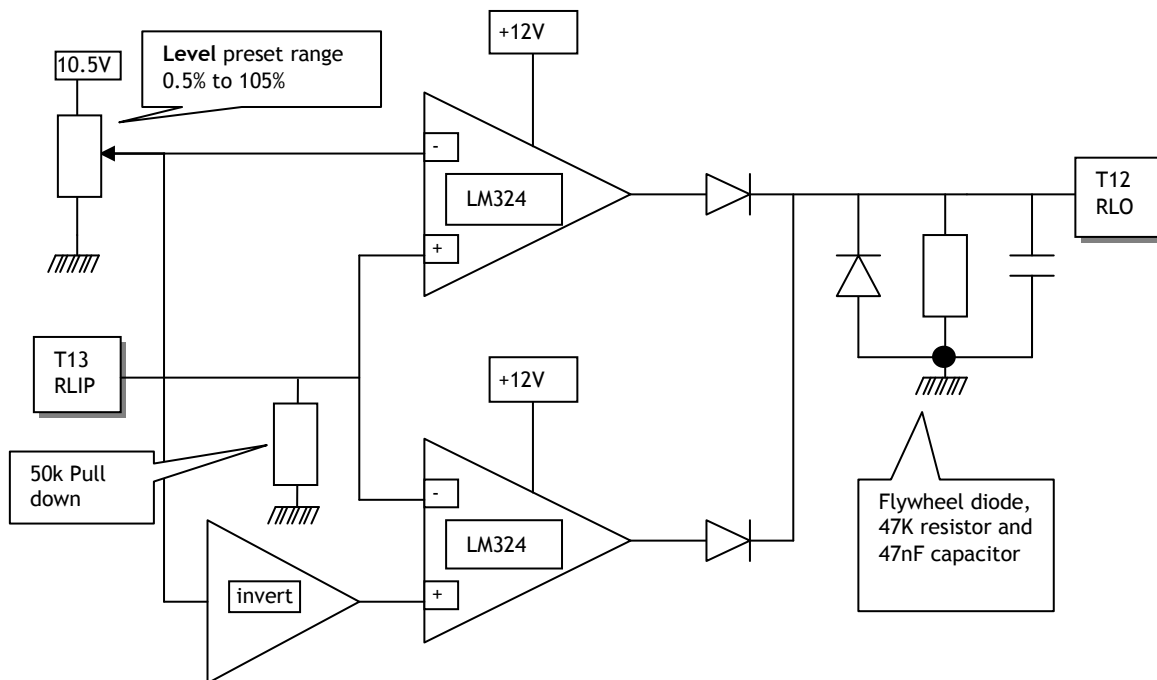

- 14 **OVL**. Overload. This output goes high (+10.5V) if the current demand exceeds 100% and the stall timer starts timing. Flywheel diode to COM. See T12 RLOP for details of the output drive capability and configuration.

Note. It stays high if the overload subsequently results in a stall trip condition.

The stall timer will allow 150% motor current for approximately 30 seconds before tripping. The overload integrator can tolerate 50% overload x 30 secs = 1500 units. (A 50% overload is 150% of motor current set on I_{max})

Available overload time prior to trip = 1500 / Overload % in seconds
 Overload time examples 125% I_{max} current for 60 secs (1500 / 25 =60)
 112.5% I_{max} current for 120 secs. (1500 / 12.5 =120)

Note. The stall timer is actuated by current demand exceeding 100% when the desired speed remains unsatisfied. E.g. Excess load, insufficient supply volts, loss of feedback, saturated feedback. insufficient torque, jammed shaft. This allows the protection to be more comprehensive than overcurrent alone.

- 15 **TRIP.** This output goes high (+10.5V) and latches high when the stall timer has timed out (in which case T14 OVLD will also be high) **OR** if the fan alarm has operated (in which case T14 OVLD will be low). Flywheel diode to COM. See T12 **RLOP** for details of the output drive capability and configuration.
- 16 **ROP.** Ramp output. 0 to +/-10V output for 0 to +/-10V input. 1K Ohm output impedance.
- 17 **DEM.** Demand output. 0 to +/-10V output for 0 to +/-100% speed demand. 1K Ohm output impedance. Represents the inverted total speed demand.
- 18 **SOP.** Speed output. 0 to +5V output for 0 to +100% speed feedback. 1K Ohm output impedance. NOTE: Prior to LA issue 11 (see side of terminal block), the output at this terminal was 0 to +10V.
- 19 **IOP.** Current output. 0 to +5V output for 0 to +100% armature current. Maximum output +7.5V for +150% current. 1K Ohm output impedance.
- 20 **SPD.** Auxiliary speed input. Added to main input. Input impedance 100K Ohm. 0 to +/-10V input for 0 to +/-100% speed demand, direct input fast response.
- 21 **TRQ.** Torque input. 100K Ohms pull up to +12V. 0 to +5V input for 0 to +/-100% current demand. This input acts as a clamp on the current demand produced by the speed loop. Also if the speed loop current demand falls below the input clamp level then the speed loop has priority. For the clamp to operate, the speed loop current demand must be arranged to exceed the clamp level by ensuring the speed demand is high enough.

- A+ Motor armature + Form Factor typically 1.5. (Load dependant)
- A- Motor armature -
- F- Motor Field - (No connection required for permanent magnet motors).
- F+ Motor Field +(For half wave field volts 0.45 X AC, connect field to F- and N).
- N AC supply. 110V AC or 240V AC +/-10%, 50-60 Hz. (30/60VAC for type LV60)
- L AC supply. 110V AC or 240V AC +/-10%, 50-60 Hz. (30/60VAC for type LV60)

Terminal tightening torques	A+ A- F- F+ N L	4.4in lb - 0.50Nm
	Terminals 1 to 21	2.2in lb - 0.25Nm

ALARMS

Models 680i and 1220i use an internal fan for cooling. The Alarm lamp will come ON and the drive will electronically shut down if the internal fan fails. (T15 **TRIP** alarm output available).

The field will remain energised, hence if the machine is to be left unattended for long periods it may cause the field to overheat.

JOGGING

For frequent stopping or jogging it is recommended to use T9 **RUN** input. When using a mains contactor, connect a spare Normally Open contact from the contactor in series with T9 **RUN** input.

BLOCK DIAGRAM

Showing wiring for ON OFF switch with ramp or coast to stop

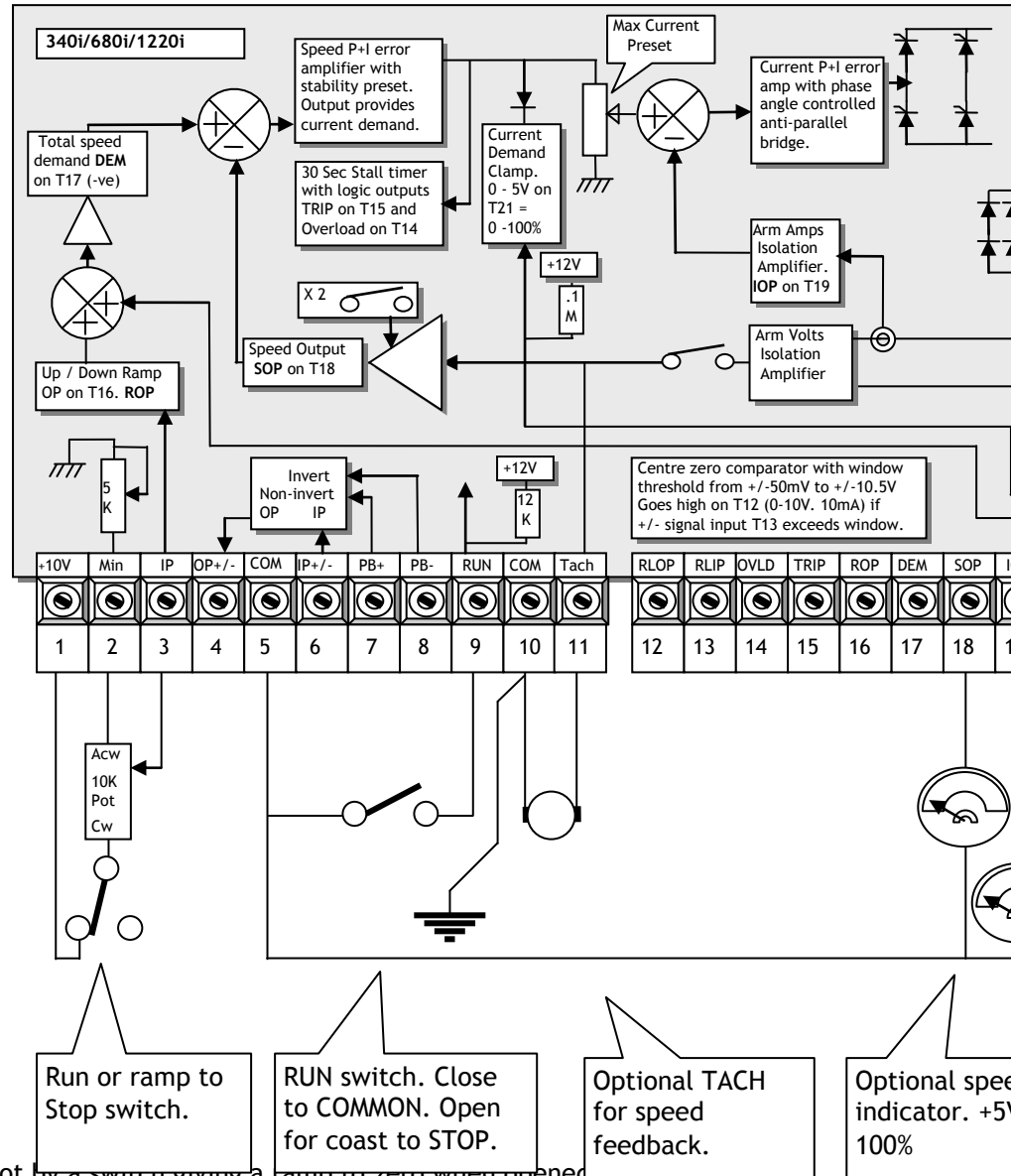

The +10V ref is connected to the speed pot by a switch giving a ramp to zero when opened.

Note. The AVF/tach select switch must be set, and the appropriate speed scale range selected for the max feedback volts, depending on the source of speed feedback.

If a tachogenerator is used the polarity on T11 must be negative with respect to COM T10.

A protective earth connection is made to terminal 10.

EMC

Special consideration must be given to installations in member states of the European Union regarding noise suppression and immunity. According to IEC 1800-3 (EN61800-3) the drive units are classified as Basic Drive Modules (BDM) only for professional assemblers and for the industrial environment. Although CE Marking is made against the EMC Directive, application of EN 61800-3 means that no RF emission limits apply. The drive manufacturer is responsible for the provision of installation guidelines. The resulting EMC behaviour is the responsibility of the manufacturer of the system or installation. The units are also subject to the LOW VOLTAGE DIRECTIVE 73/23/EEC and are CE marked accordingly.

Following the procedures outlined will normally be required for the drive system to comply with the European regulations, some systems may require different measures. Installers must have a level of technical competence to correctly install.

Power supply port

The power supply port is subject to alternative guidelines, as described below. Compliance with emissions limits on this port may or may not be required depending on the environment. If required then compliance can be achieved by fitting a separate filter unit, contact supplier for details.

EN61800-3 specifies 2 alternative operating environments. These are the domestic (1st environment) and industrial (2nd environment). There are no limits specified for conducted or radiated emissions in the Industrial environment, hence it is usual for the filter to be omitted in industrial systems.

Definition of an industrial environment: Includes all establishments other than those directly connected to a low voltage power supply network which supplies buildings used for domestic purposes.

In order to meet mains conducted emissions limits on this port for the 1st environment, a separate filter is required. Please refer to supplier for a suitable filter (EN 61800-3 restricted distribution, domestic environment).

Earthing and screening guidelines

A separate earth conductor is taken from the motor housing and is run adjacent to the drive conductors right up to the main earth terminal in the enclosure. This conductor should not be grounded separately to any other earth point.

The drive protective earth on Terminal 10 should be separately taken to the cabinet star earth point.

Motor drive and three-phase supply cables should be segregated from other cables in the cabinet, preferably by a distance of at least 300mm. They can be screened or armoured, especially if they pass near other sensitive apparatus, and the screening should be bonded to the motor housing and the point of entry of the cabinet using 360° gland techniques.

It is understood that the bonding of both ends of the screening and earth conductors may result in significant earth current flow if the motors and control cabinet are in widely different locations, so that there are large earth potential differences. In these circumstances it is recommended that a separate parallel earth conductor (PEC), which may be a bonded metal conduit, is used alongside the drive cables to give a preferential route for this current. See IEC 61000-5-2 for more detail. Installation in conformance with this standard is regarded as good practice and will result in improved EMC of the whole system.

WARNING Safety earthing always takes precedence over EMC earthing.

Guidelines when using filters

Filter Part number FRLN16.

IMPORTANT SAFETY WARNINGS		
	<p>The AC supply filters must not be used on supplies that are un-balanced or float with respect to earth</p>	<p>The drive and AC filter must only be used with a permanent earth connection. No plugs/sockets are allowed in the AC supply</p>
		<p>The AC supply filter contains high voltage capacitors and should not be touched for a period of 20 seconds after the removal of the AC supply</p>

- 1) The AC connections from the filter to the drive must be less than 0.3m or if longer correctly screened.
- 2) The AC filter and motor cable screen should connect directly to the metal of the cabinet.
- 3) Do not run filtered and unfiltered AC supply cables together.
- 4) The AC input filter has earth leakage currents. RCD devices may need to be set at 5% of rated current.
- 5) The AC supply filter must have a good earth connection to the enclosure back plane. Take care with painted metal. Remove paint and ensure good connection.

MECHANICAL DETAILS

The product is enclosed in a stylish DIN rail mounted enclosure with plug in screw terminal connections.

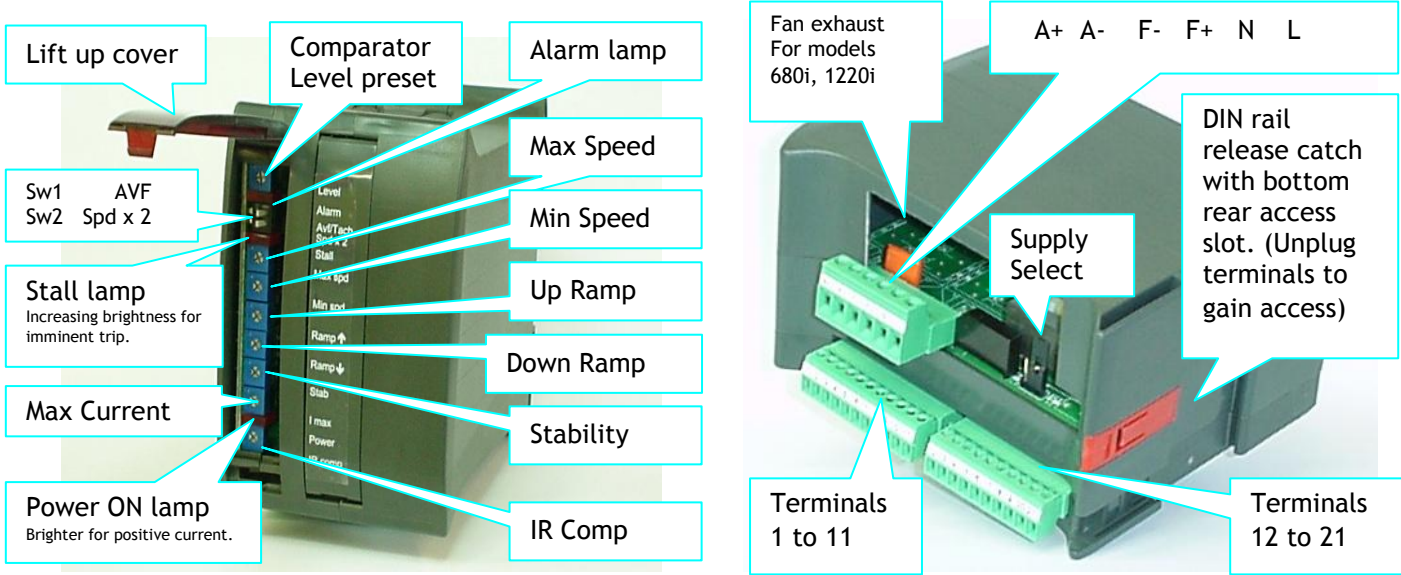

	Height	Width	Depth
340i	105	60	120
680i	105	70	120
1220i	105	70	120

Earthing A clean signal earth Connection should be made to Terminal 10 (Common). The motor earth should be connected to the earth in the system enclosure.

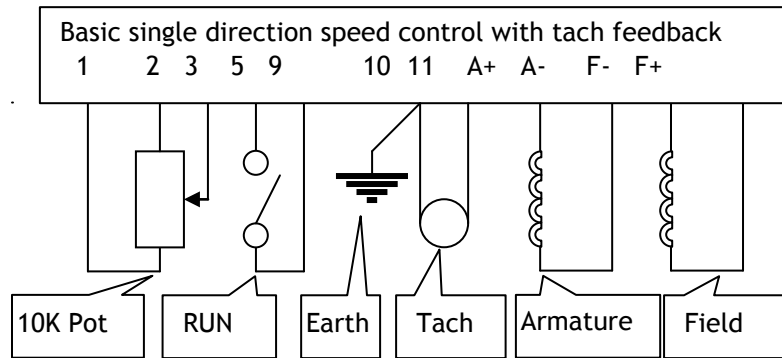

WARNINGS

Health and safety at work. Electrical devices constitute a safety hazard. It is the responsibility of the user to ensure compliance with any acts or bylaws in force. Only skilled persons should install

this equipment. Sprint Electric Ltd does not accept any liability whatsoever for the installation, fitness for purpose or application of its products. It is the users responsibility to ensure the unit is correctly used and installed.



UL file E168302



Sprint Electric Limited, Arundel, UK
 Tel. +44 (0)1903 730000
 Fax. +44 (0)1903 730893
 Email. info@sprint-electric.com